

VPX1PH3UC310-SA

Overview

3U VPX AC-DC Power Converter Card
 85-264Vac (47-63Hz /360-800Hz) Single Phase Input
 2 Outputs, 310W Max Combined Output

Market(s)

Defense

Typical Application(s)

Embedded Computing, C4ISR



Product Highlights

This single slot thin (5HP) power card offers filtered single-phase AC input and provides +12V and +3.3V_AUX outputs in alignment with the SOSA™ Technical Standards. With 310W maximum output power, it is a COTS military power supply solution designed to meet applicable portions of MIL-STD-810F vibration and shock, VITA 62 Modular Power Supply and VITA 48.2 conduction-cooled requirements. The VPX1PH3UC310-SA provides users with high AC-DC efficiency (up to 89%), small form capture (3U x 5hp), and high power (up to 310W). Alignment keys offer keying options when using multiple power supplies in one chassis. Redundant IPMB bus and I2C functionality allows users to monitor sensor data (temperature, voltage, current, counter), obtain device ID, and retrieve self-test results per VITA 46.11 and SOSA™ Technical Standards.

Features

- 85-264Vac (47-800Hz)
- 2 Output Voltages, 310W
- Single-Slot 5HP VITA 48.2 VPX Power Card
- ANSI/VITA 46.11 Tier 2 IPMC *
- Redundant IPMB bus connections

* Designed to meet applicable portions of this standard. Contact Aegis Power Systems, Inc. for specific details.

Table 1: Maximum Continuous Operating Ratings

Parameter	Rating	Unit	Notes
Vin max range	85 to 264	Vac	115Vac nominal
Temperature (Operating)	-40 to +85	°C	Baseplate @ wedgelocks (See Table 4)
Input power	374	W	@ 115Vac input
	365	W	@ 230Vac input
Combined output power	310	W	See Table 2 for DC output variations
Efficiency	87	%	Typical @ 115Vac input
Efficiency	89	%	Typical @ 230Vac input

About Us

Aegis Power Systems, Inc. specializes in the design, development, and manufacture of AC-DC and DC-DC power supplies for high-performance, rugged, critical, and specialty applications. Markets served include defense, industrial, communications, aircraft, shipboard, rack mount, embedded computing, and electric vehicle applications.

[Contact us](#) to find out if this item can be custom configured or redesigned to meet your specific technology need.

SPECIFICATIONS

(Typical at 25°C, nominal line and 100% load, unless otherwise specified.)

Parameter	Notes
Input Voltage	85-264Vac (47-63Hz /360-800Hz) (250W max output when Vin<90Vac)
Input Current	1.59A @ 230Vac input, 3.25A max @ 115Vac input (310W out).
Input Power	365W max @ 230Vac input / 374W max @ 115Vac input (310W output).
Total Output Power	310W max. all outputs combined (see Table 4).
Output Voltages	(see Table 2).
Hold-Up (during power loss)	15ms@310W output
Efficiency	89% typical @ 230Vac input, 87% typical @ 115Vac input. 85% minimum @ 230Vac input, 83% minimum @ 115Vac input.
Power Factor	.99 @ 60Hz, .97 @ 400Hz.
Start-Up Time	2 second maximum.
Voltage Set Point	+/- 5% V Out nominal (for any combination).
Line/Load Regulation	+/- 5% V Out nominal (for any combination).
Output Ripple	50mVpk-pk Max. (20 MHz BW) all except; +/-12 Vdc 120mVpk-pk Max.
Current Limit	Short circuit protected with automatic recovery.
Temperature	-40°C to +85°C Operating baseplate @ 310W output -55°C to +125°C Storage.
Cooling	Conduction cooling through wedgelocks to customer rack.
Package	Single slot pluggable slide in rack card.
Dimensions	3U x 5hp x 168.49mm (see mechanical drawing page) (VITA 48.2 Table 3).
Weight	1.55 lbs. (typical).
Connectors	1ea TE Connectivity 6450849-7 or equivalent (see Table 5).
Vibration	Designed to meet – ANSI/VITA 47-2005 (R2007), Section 4.4.3 Vibration Class V3. MIL-STD-810F, Method 514.5, Procedure I.
Shock:	Designed to meet - ANSI/VITA 47-2005 (R2007), Section 4.5.2 Operating Shock Class OS2. ANSI/VITA 47-2005 (R2007), Section 4.5.3 Bench Handling Shock. MIL-STD-810F, Method 516.5, Procedure I.
Humidity	0 – 95% non-condensing per ANSI/VITA 47-2005 (R2007), Section 4.6 Humidity.
EMI	Designed to meet MIL-STD-461G conducted emissions (external EMI filter may be required).
System Management	VITA 46.11 IPMI I2C interface with monitoring & dual IPMB bus (see Table 6).

Specifications subject to change without notice.

Table 2: Voltage Output (Nominal)

	VS1	3.3V_AUX
VPX1PH3UC310-SA	+12VDC @ 310W	3.3VDC_AUX @ 66W
* Output power levels indicate maximum power available per output. Total combined power of all outputs on VPX1PH3UC310-SA cannot exceed 310W.		

Table 3: ENABLE / INHIBIT

Control Inputs		Power Outputs	
ENABLE	INHIBIT	3.3V_AUX	VS1
High	High	Off	Off
High	Low	Off	Off
Low	High	On	On
Low	Low	On	Off

Table 4: Power Derating

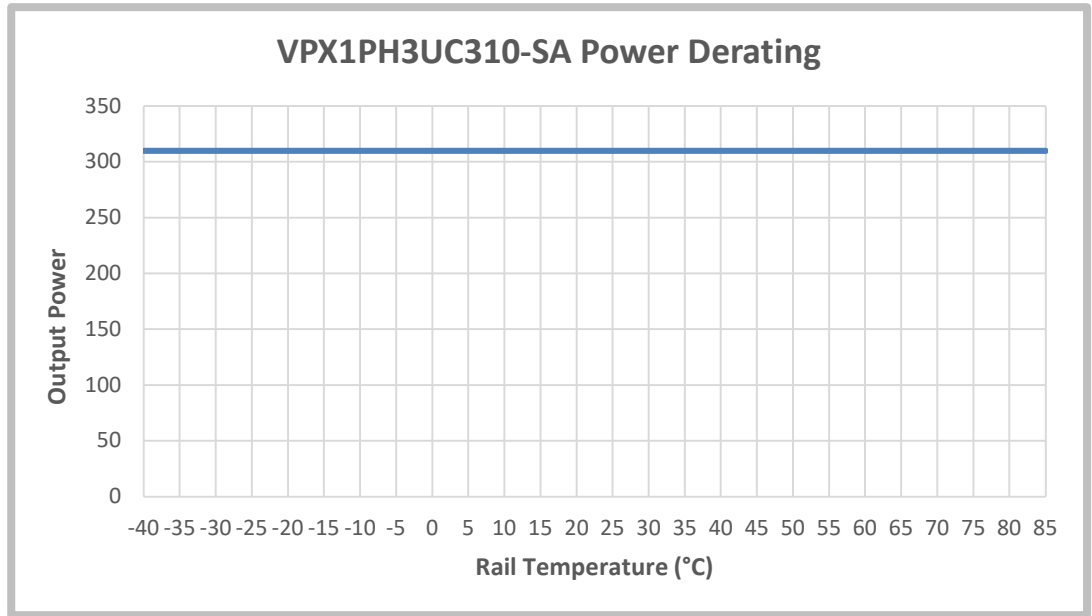

Table 5: Connector Specifications

TE Connectivity Connector 6450849-7 or equivalent

Contact Designation		Conductor Circuit
P1	40A	-DC_IN/ACN
P2	40A	+DC_IN/ACL
LP1	20A	CHASSIS
A1	<1A	(NC)
B1	<1A	(NC)
C1	<1A	GA2*
D1	<1A	(NC)
A2	<1A	(NC)
B2	<1A	FAIL*
C2	<1A	INHIBIT*
D2	<1A	ENABLE*
A3	<1A	(NC)
B3	<1.5A	(NC)
C3	<1A	(NC)
D3	<1A	(NC)
A4	<1.5A	(NC)
B4	<1.5A	(NC)
C4	<1.5A	(NC)
D4	<1.5A	(NC)
A5	<1A	GA0*
B5	<1A	GA1*
C5	<1A	SM0 (I2C/SCL)
D5	<1A	SM1 (I2C/SDA)
A6	<1A	SM2 (I2C/SCL)
B6	<1A	SM3 (I2C/SDA)
C6	<1.5A	(NC)
D6	<1A	SYSRESET*
A7	<1A	(NC)
B7	<1A	(NC)
C7	<1A	(NC)
D7	<1A	SIGNAL_RETURN
A8	<1A	+12VDC SENSE
B8	<1A	+3.3V_AUX SENSE
C8	<1A	+12VDC SENSE
D8	<1A	SENSE_RETURN
P3	40A	+12VDC (VS1)
P4	40A	POWER_RETURN
P5	40A	POWER_RETURN
LP2	20A	+3.3V_AUX
P6	40A	+12VDC (VS1)

* Use of a trailing asterisk indicate a logic signal which is active when at the less positive level of its allowable range

Table 6: IPMI Commands

The following three VITA 46.11 IPMI commands are currently implemented in firmware:

- Get Device ID Command (App (06h) (01h))**
 This command will return the hardware revision, firmware/software revision, command interface revision, system serial number for the power supply.
- Get Self-Test Results Command (App (06h) (04h))**
 This command will initiate the power supply to verify all available sensor readings are within specified operating ranges. It will report successful if there are no errors, or it will report the sensor that was out of range.
- Get Sensor Reading Command (S/E (04h) (2Dh))**
 This command will return the data from one of the available sensors. The following sensors are available:

Self-test Sensor Threshold	Sensor Number	Available Data Sensors	Data Reply Format
OT = 105C	00h	BASEPLATE TEMPERATURE	2 BYTE HEX
OV/UV = +/-5%	01h	VS1 OUTPUT VOLTAGE	2 BYTE HEX
OV/UV = +/-5%	05h	+3.3V_AUX OUTPUT VOLTAGE	2 BYTE HEX
OC = 120% Nom.	07h	VS1 OUTPUT CURRENT	2 BYTE HEX
OC = 120% Nom.	08h	+3.3V_AUX OUTPUT CURRENT	2 BYTE HEX
N/A	0Ah	TURN-ON COUNTER	2 BYTE HEX

DWG NO.		2		SH	REV
REVISIONS					
ZONE	REV	DATE		APPROVED	
	A01	INITIAL RELEASE		DD/MM/YY	XX

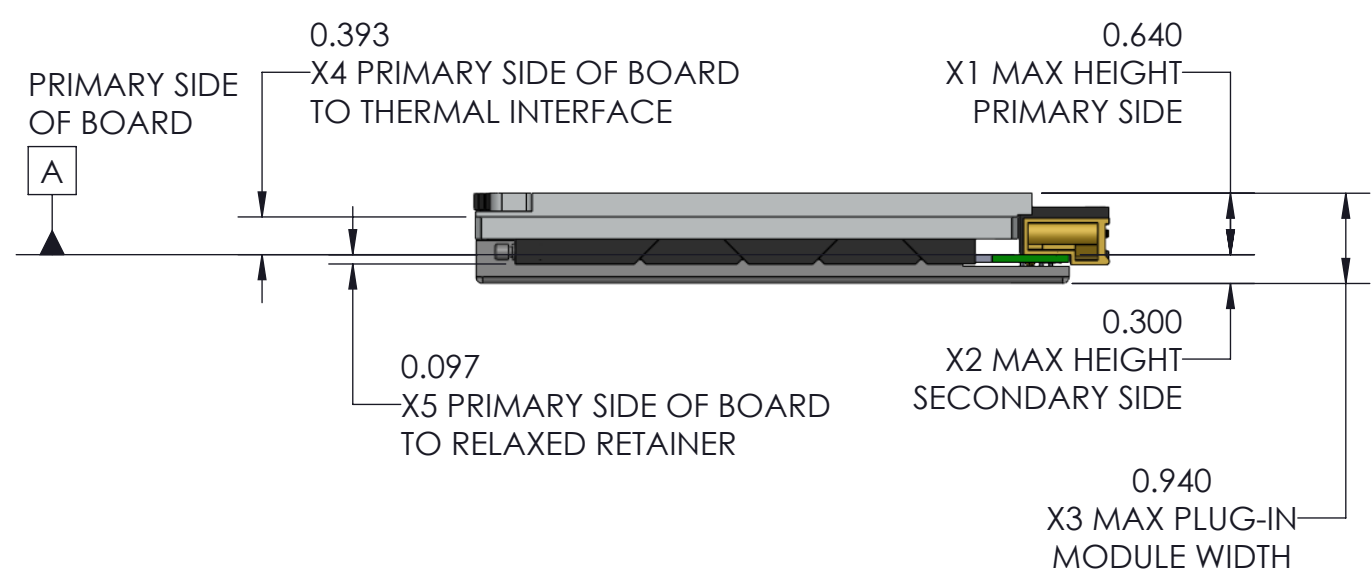
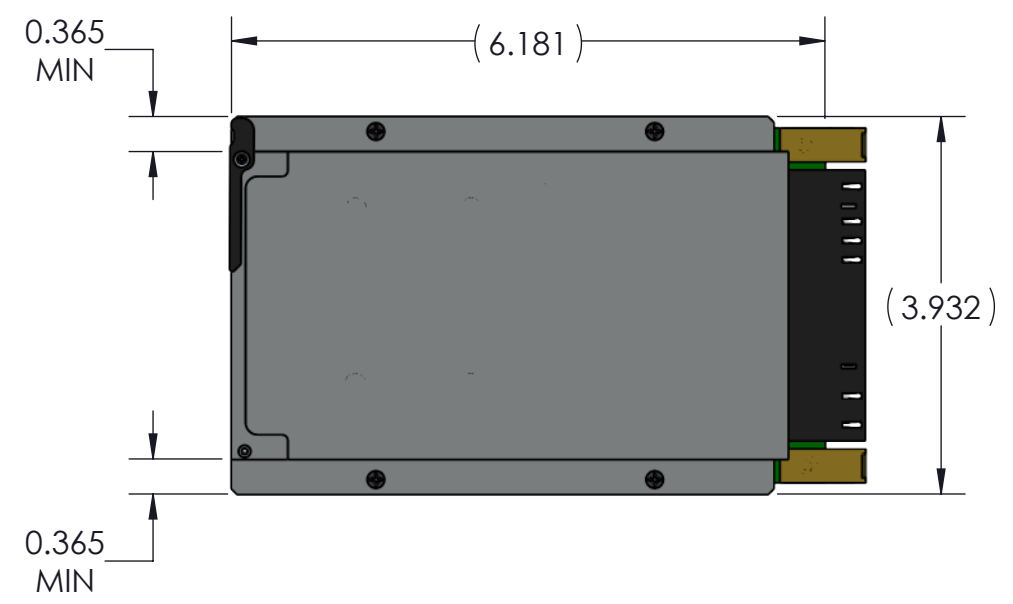

AEGIS POWER SYTEMS, INC. PROPRIETARY INFORMATION. NODISCLOSURE, REPRODUCTION, OR USE OF ANY PARTY HERE OF MAY BE MADE EXECEPT BY EXPRESS WRITTEN PERMISSION OF AEGIS POWER SYTEM, INC.

UNLESS OTHERWISE SPECIFIED:
 DIMENSIONS ARE IN INCHES
 TOLERANCES:
 FRACTIONAL ± N/A
 DEGREES: ± .5
 TWO PLACE DECIMAL ± .02
 THREE PLACE DECIMAL ± .005

CONTRACT NO.		
APPROVALS	NAME	DATE
DRAWN		
CHECKED		
ENG APPR.		
MFG APPR.	RP	
Q.A.	MH	

**AEGIS POWER SYSTEMS
MURPHY, NORTH CAROLINA**

TITLE:
VPXxx3UCxx-
 AEGIS P/N: VPXxx3UCxx-

MATERIAL: SEE NOTE 3
 FINISH: SEE NOTE 4
 DO NOT SCALE DRAWING

COMMENTS:
 GENERATED:BY SOLIDWORKS

SIZE	FSCM NO.	DWG. NO.	REV
B	06ES8	VPXxx3UCxx	
SCALE: 1:2		SHEET 1 OF 1	